

PERMCO **TWO-SPEED MOTORS**

3100/5100 SERIES TWO-SPEED MOTORS **SMALL/MEDIUM DISPLACEMENT ROLLER BEARING SERIES**



P5100 SERIES TWO-SPEED

TWO-SPEED SERIES FEATURES

- Roller bearing design in small and medium frame sizes
- High start-up torque values for winch and low-speed applications
- Built-in two-speed valving for either low-speed/high torque or high-speed/low torque modes with shift on the fly capabilities
- Utilizes standard tooth count or winch motor high tooth count alloy steel gear and shaft sets depending on application
- Special ring seals and pressure balanced wear plates maintain high motor efficiency throughout all operating ranges
- Doweled and high strength cast iron construction
- A wide range of porting, mounting, and shaft options available
- Displacements from 49.1 through 210.5 ml/r
- Working pressure up to 21 MPa
- Speeds up to 2400 RPM
- 100% factory tested per application specifications



The Sensible Choice

Dimensional Data (mm)

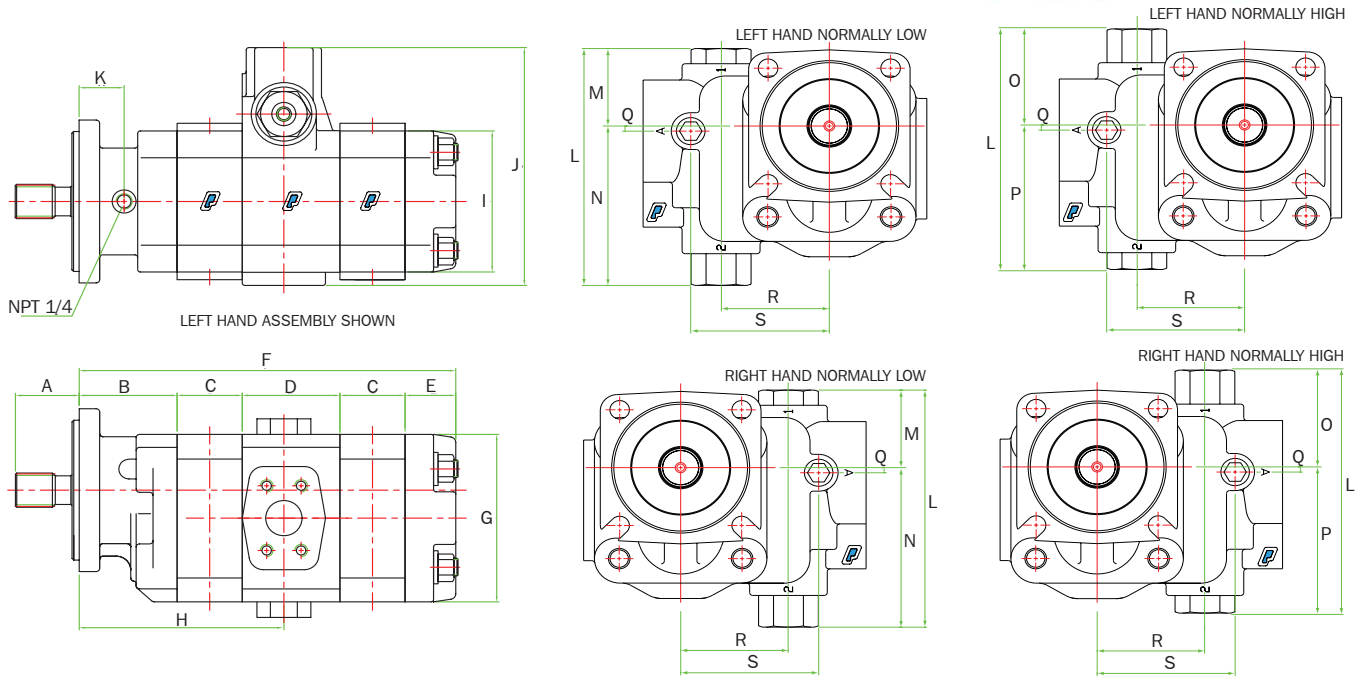

Model	A	B	C	D	E	F	G	H	I	J	K	L	M	N	O	P	Q	R	S
3000/3100	See Drive Shaft Codes in Engineers Handbook	74.67	19.1 + GW	85.85	44.45	243 + TGW	140	(CW) 143 + GW(F)	122.1	213 (JIC)	38.10	184.1	64.26	119.9	76.96	107.2	0.787	79.50	101.6
								(CCW) 130 + GW(F)		208 (SF)									
5000/5100	See Drive Shaft Codes in Engineers Handbook	85.85	19.1 + GW	85.85	44.45	254 + TGW	159	(CW) 154 + GW(F)	128.5	216 (JIC)	39.62	184.1	64.26	119.9	76.96	107.2	3.962	79.50	101.6
								(CCW) 141.5 + GW(F)		208 (SF)									

GW = GEAR WIDTH TGW = TOTAL GEAR WIDTH (FRONT AND REAR GEAR SECTIONS) GW(F) = GEAR WIDTH (FRONT SECTION)
 CW = CLOCKWISE ROTATION CCW = COUNTER CLOCKWISE ROTATION JIC = O'RING STRAIGHT THREAD SF = SPLIT FLANGE

Permco's Two-Speed motors have the two-speed valve built into the bearing carrier providing compact packaging and offering lower system cost by eliminating expensive external components. The two-speed valve can be shifted on the fly to either low speed/high torque or high speed/low torque modes.

Two-Speed motors are ideal for winch, crawler, conveyor, auger and many other types of applications with low speed/high torque and high speed/low torque requirements. In winch or over hung load applications a counterbalance valve should be included in the hydraulic circuit; the counterbalance valve can be mounted directly to the bearing carrier outlet port if needed. It should be noted that two-speed motors should not be used in applications where counterbalancing in both directions is required.

Two-speed motors can be constructed with our ten-tooth count standard motor (M) gears or our thirteen-tooth count winch motor (W) gears depending on the application. In low speed/high torque applications (below 400 RPM) it is best to utilize the thirteen-tooth winch motor (W) gears; this will provide improved starting torque, smoother low speed operation and lower torque ripple.

Typical starting torque is up to 80%+ of theoretical in the low speed mode utilizing winch motor (W) gears. Typical running torque is 4.59 N-m per 1" of gear per 1 MPa for the M3000/3100 and W3000/3100 series (32.8 ml/r per 1" gear) and 5.90 N-m per 1" of gear per 1 MPa for the M5000/5100 and W5000/5100 series (42.2 ml/r per 1" gear). Operating pressures range up to 21 MPa dependent on gear size and configuration. Refer to Permco's Engineer's Handbook for available gear sizes and maximum operating pressures. Case drain required in most applications with less than .69 MPa backpressure; consult factory.

Note: When ordering please specify right hand (CW) or left hand (CCW) orientation, low or high speed start-up, operating RPM's and pressures for high and low speed modes.

In accordance with our policy of continued product development, we reserve the right to change specifications without notice. The data is average test data and should not be misconstrued to represent performance of each units.

Permco
 1500 Frost Rd.
 P. O. Box 2068
 Streetsboro, OH 44241

Phone 330-626-2801
 Fax 330-626-2805
 e-mail info@permco.com
 www.permco.com

Permco Hydraulik AG
 P. O. Box 553
 6343 Rotkreuz
 Switzerland
 e-mail: heinzm@permco.com

Permco (Tianjin) Hydraulics Inc., Ltd.
 236 Jinbindadao Free Trade Zone
 TianJin Port, China
 e-mail: technic@permcotj.com
 www.permcotj.com